



MPS
6529
SINGLE-PORT
INTERFACE

6529 SINGLE PORT INTERFACE

DESCRIPTION

The 6529 is a static microprocessor compatible, 8-bit I/O Port with passive output pull-up devices. Data is written to the port when \overline{CS} and R/W are low. Data is read from the port when \overline{CS} is low and R/W is high. The passive output pull-ups allow a single bit to act as either an input or an output without I/O mode switching.

This device is provided with special circuitry to provide power-on reset. Under normal fast power-on conditions the outputs will initialize in the input high impedance state. With very slow or noisy power-up, there is some possibility the device will initialize with outputs driven low. It is recommended that the 6529 be interfaced to open collector output type devices.

TRUTH TABLE

CS	R/W	D ₀ -D ₇
L	L	DATA BUS TO PORT
L	H	PORT TO DATA BUS
H	X	ISOLATION

L = LOW Level
H = HIGH Level
X = Irrelevant

PIN CONFIGURATION

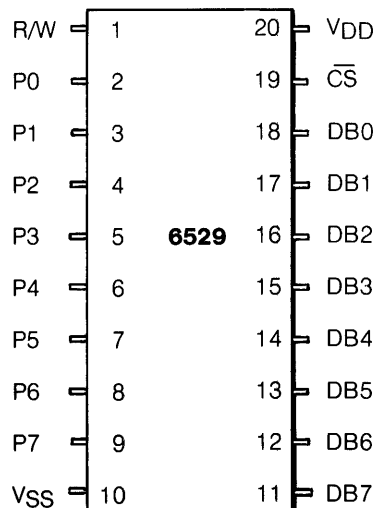

ORDER INFORMATION

MXS 6529

FREQUENCY RANGE
NO SUFFIX = 1 MHz
A = 2 MHz
B = 3 MHz

PACKAGE DESIGNATOR
C = Ceramic
P = Plastic

MPS
6529
MAXIMUM RATINGS

RATING	SYMBOL	VALUE	UNIT
SUPPLY VOLTAGE	V _{CC}	-0.3 to +7.0	V _d c
INPUT VOLTAGE	V _{in}	-0.3 to +7.0	V _d c
OPERATING TEMPERATURE RANGE	T _A	0 to +70	°C
STORAGE TEMPERATURE RANGE	T _{stg}	-55 to +150	°C

This device contains circuitry to protect the inputs against damage due to high static voltages, however, it is advised that normal precautions be taken to avoid application of any voltage higher than maximum rated voltages to this circuit.

CHARACTERISTICS (V_{CC} = 5.0V ± 5%, V_{SS} = 0V, T_A = 0° to 70°C)

CHARACTERISTIC	SYMBOL	MIN	MAX	UNIT
Input High Voltage (Normal Operating Levels)	V _{IH}	+2.0	V _{CC}	V _d c
Input Low Voltage (Normal Operating Levels)	V _{IL}	-0.3	+0.8	V _d c
Input Leakage Current V _{in} = 0 to 5.0V _d c WRITE, CS	I _{IN}	—	±2.5	μA _d c
Three-State (Off State Input Current) V _{in} = 0.4 to 2.4 V _d c, V _{CC} = Max D ₀ -D ₇	I _{TSI}	—	±10	μA _d c
Output High Voltage V _{CC} = Min, Load = -600μA _d c, P ₀ -P ₇ V _{CC} = Min, Load = -200μA _d c, D ₀ -D ₇	V _{OH}	2.4	—	V _d c
Output Low Voltage V _{CC} = Max, Load = 6.4mA _d c, P ₀ -P ₇ V _{CC} = Max, Load = 3.2mA, D ₀ -D ₇	V _{OL}	—	+0.4	V _d c
Output High Current (Sourcing) V _{OH} = 2.4 V _d c	P ₀ -P ₇ D ₀ -D ₇ I _{OH} I _{OH}	-600 -200	—	μA _d c μA _d c
Output Low Current (Sinking) V _{OL} = 0.4 V _d c	P ₀ -P ₇ D ₀ -D ₇ I _{OL} I _{OL}	6.4 3.2	—	mA _d c mA _d c
Supply Current	I _{CC}	—	80	mA

NOTE: Negative sign indicates outward current flow, positive indicates inward flow.

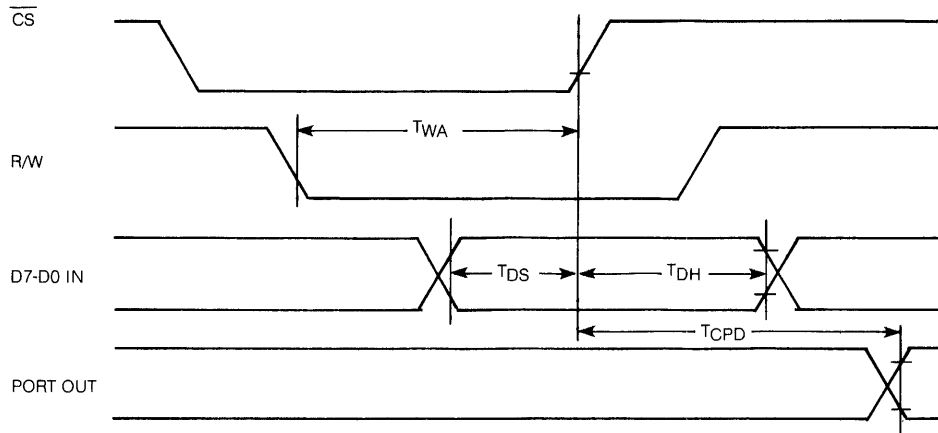
MPS
6529
6529 WRITE CYCLE TIMING DIAGRAM

Note: All timings referred to V_{ILmax} , V_{IHmin} for inputs and V_{OLmax} , V_{OHmin} for outputs.

6529 WRITE CYCLE CHARACTERISTICS

Symbol	Characteristic	1 MHz		2 MHz		3 MHz		UNIT
		MIN	MAX	MIN	MAX	MIN	MAX	
T_{WA}^*	Write Active	450	—	225	—	160	—	ns
T_{CPD}	\overline{CS} to Port Out Delay	—	1000	—	500	—	330	ns
T_{DS}	Data to \overline{CS} Setup	150	—	100	—	100	—	ns
T_{DH}	Data to \overline{CS} Hold	0	—	0	—	0	—	ns

* T_{WA} is the time while both \overline{CS} and R/W are low



MPS
6529

6529 READ CYCLE DIAGRAM

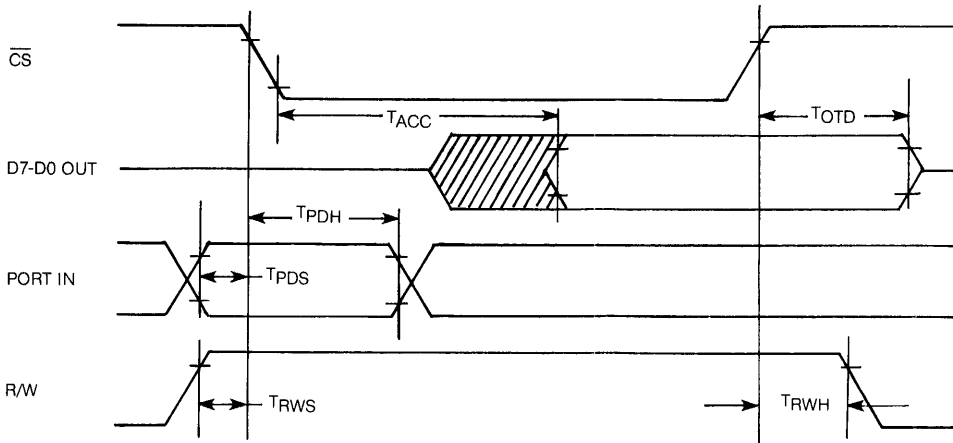

Note: All timings referenced to V_{IL} max, V_{IH} min for inputs and V_{OL} max, V_{OH} min for outputs.

6529 READ CYCLE CHARACTERISTICS

Symbol	Characteristic	1 MHz		2 MHz		3 MHz		UNITS
		MIN	MAX	MIN	MAX	MIN	MAX	
T_{ACC}	Access Time	—	450	—	225	—	160	ns
T_{PDS}	Port Input Setup	120	—	60	—	40	—	ns
T_{PDH}	Port Input Hold	30	—	30	—	30	—	ns
T_{RCS}	R/W to \overline{CS} Setup	0	—	0	—	0	—	ns
T_{RCH}	R/W to \overline{CS} Setup	0	—	0	—	0	—	ns
T_{OTD}	\overline{CS} to Output Off Delay	20	120	20	120	20	120	ns

COMMODORE SEMICONDUCTOR GROUP reserves the right to make changes to any products herein to improve reliability, function or design. COMMODORE SEMICONDUCTOR GROUP does not assume any liability arising out of the application or use of any product or circuit described herein; neither does it convey any license under its patent rights nor the rights of others.